



Products: R&S® SFU Broadcast Test System

Generating Interference Signals Using the R&S® SFU-K37 Option

Application Note

This Application Note introduces the new interferer management option, R&S® SFU-K37 and describes how this can be used to generate various types of interfering signals for testing the performance of a receiver.



Contents

1 Overview.....	2
2 Introducing the R&S® SFU-K37 Option.....	2
Interferer Source.....	3
Interferer Attenuation.....	5
Interferer Frequency Offset.....	7
Interferer Addition.....	8
Signal Frequency Offset.....	9
3 Basic Measurement Techniques.....	11
4 The Performance of the R&S® SFU-K37 Interferer Option.....	14
Adjacent Channel Tests in Line With IEC 62002-2.....	14
Performance Clearance of the R&S® SFU-K37 Interferer Option.....	17
5 Summary.....	17
6 References.....	18
7 Ordering Information.....	19

1 Overview

Very often, a receiver is subject to interference from a nearby frequency channel. This has an impact on the dynamic range of the receiver to receive the wanted signal. Thus, adjacent channel interference is an important consideration for any communications system.

Depending on the characteristics of the interfering signal relative to the intended signal, the receiver may be able to achieve a satisfactory level of reception. This is dependent on the strength, frequency offset as well as the crest factor of the interferer.

Hence, for a receiver manufacturer, the ability to generate a set of different patterns for the interfering signal is an essential requirement to determine the reception quality of the receiver [1].

This Application Note introduces the new option in the R&S® SFU broadcast test system which is capable of generating a series of pre-defined and user-defined interferers.

2 Introducing the R&S® SFU-K37 Option

The objective of the R&S® SFU-K37 option is to generate besides the useful signal an interferer for the purpose of testing the immunity of a receiver against such additional interference signals. The flexibility offered by this option enables the user to manipulate the following properties of the interferer:

1. Interferer Source
2. Interferer Attenuation
3. Interferer Frequency Offset
4. Interferer Addition

In addition, the user can also adjust the frequency offset of the signal relative to the interferer.

Fig. 1 shows a typical menu of the interferer management on the R&S® SFU

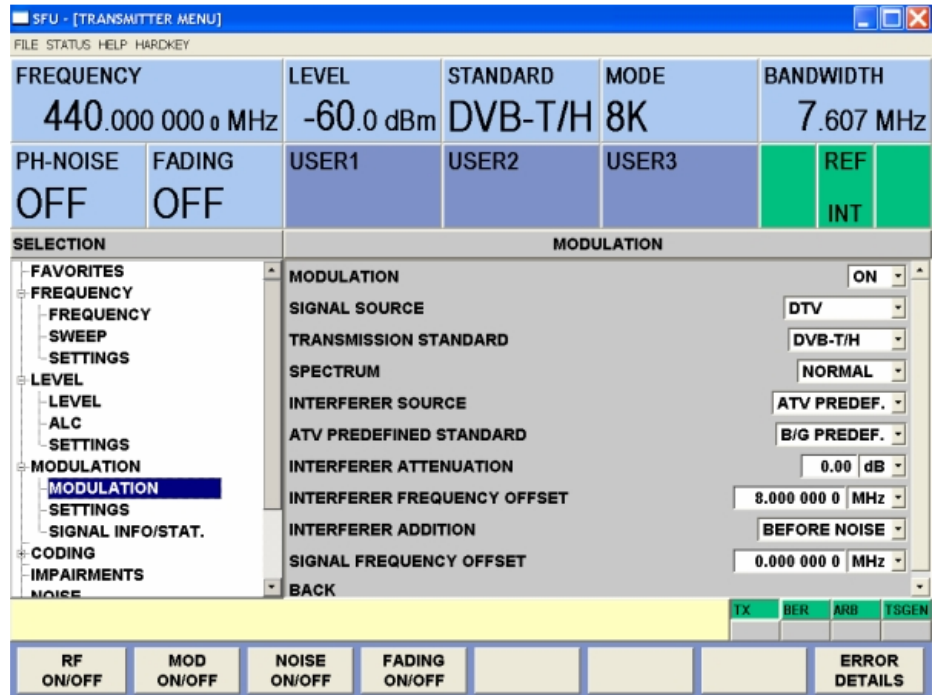

Fig. 1 The menu display for the interferer on the R&S® SFU

Interferer Source

The source of the interferer can be either pre-defined in the R&S® SFU or from an external signal source such as an I/Q waveform generator. The following selections are possible:

1. None (*this will turn off the interferer*)
2. ATV Predef
3. ARB
4. I/Q Digital
5. I/Q Analog

Selecting the **ATV Predef** function will open up another menu which offers a further selection of the various analog TV standard signals.

One-channel standards	Analog multi-interferer signals	Combined analog/digital multi-interferer signals
B/G PREDEF. B/G N PREDEF. D/K PREDEF. I PREDEF. M/N PREDEF. L PREDEF.	2 CH. PAL B (MBRAI) 2 CH. PAL G (MBRAI) 2 CH. PAL B N (MBRAI) 2 CH. PAL G N (MBRAI) 2 CH. PAL I1 (MBRAI) 2 CH. SECAM L (MBRAI)	DVB-T + PAL B (MBRAI) DVB-T + PAL G (MBRAI) DVB-T + PAL B N (MBRAI) DVB-T + PAL G N (MBRAI) DVB-T + PAL I1 (MBRAI) DVB-T + SECAM L (MBRAI)

For the **ARB** menu item, the interferer signal should be defined within the ARB option (requires R&S[®] SFU-K35 installed in the R&S[®] SFU) menu. Load a waveform from the hard-disk storage in the ARB generator of the R&S[®] SFU and this will become the interferer signal. For example, in order to have MBRAI-compliant double DVB-T interference signals, the R&S[®] SFU-K354 is required.

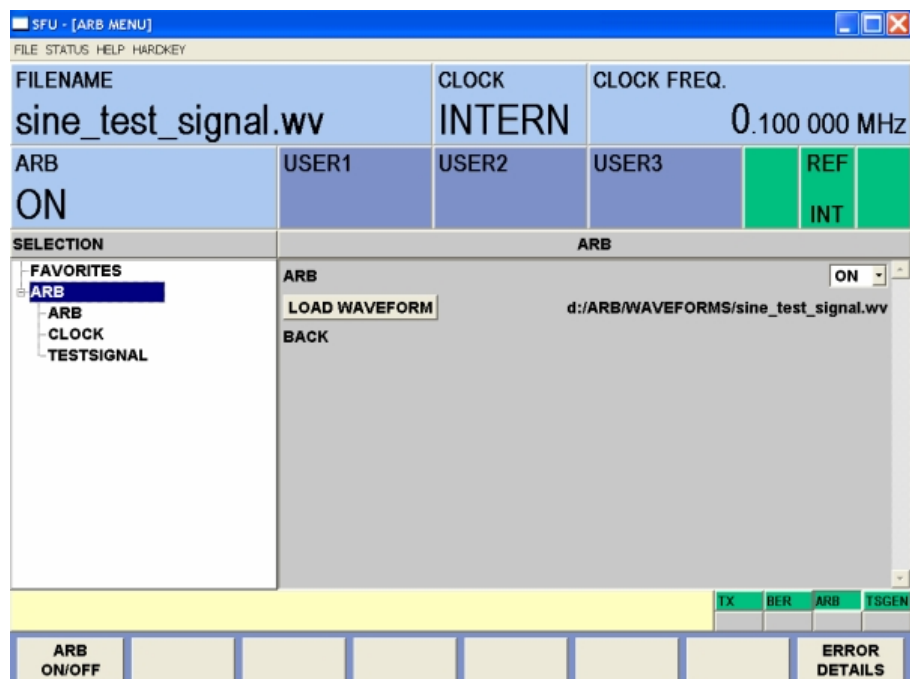

Fig. 2 The ARB interferer signal is loaded from the ARB menu of the R&S[®] SFU

If the **I/Q Digital** option for the interferer source is selected, an I/Q signal source is injected at the connection at the rear of the R&S[®] SFU as shown in Fig. 3.

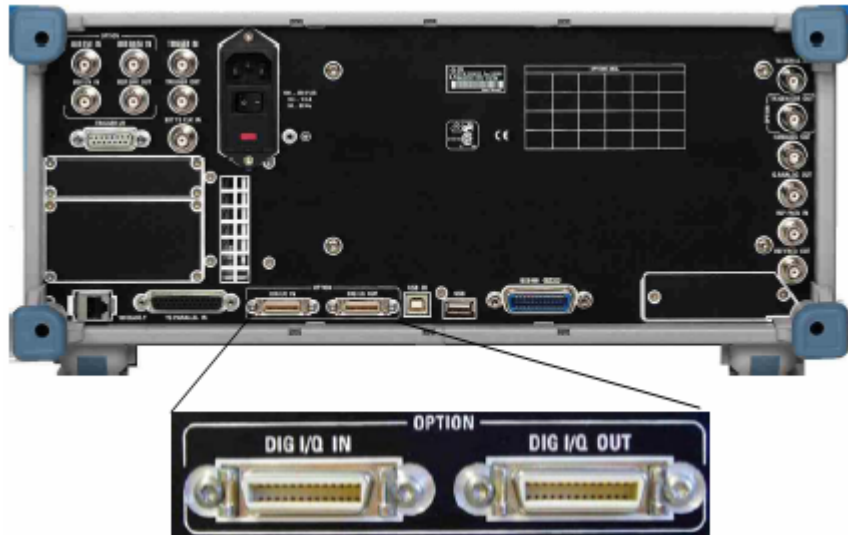

Fig. 3 The I/Q digital interferer signal is injected into the **DIG I/Q IN** connector at the rear of the R&S® SFU

Similarly, for the **I/Q Analog** option, an analog I/Q signal source is injected at the connector at the front of the R&S® SFU as shown in Fig. 4.

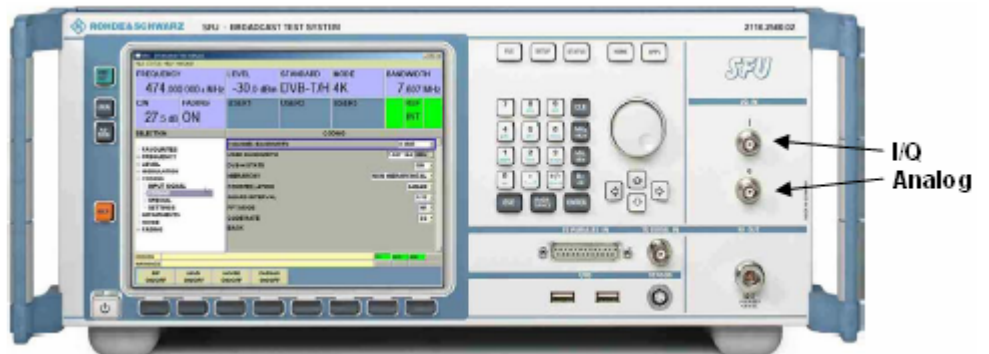

Fig. 4 The I/Q analog interferer signal is injected into the **I/Q IN** connector at the front of the R&S® SFU

Interferer Attenuation

The level of the interferer signal can be defined by this setting. The maximum and minimum allowable level of the interferer is specified as 60 dB and -60 dB respectively. This value is the level difference between the interferer power and the useful signal power. Thus a +xx dB value means an interferer level below and a -xx dB value an interferer level above the useful signal.

An example of the power level of both interferer and signal can be viewed on a spectrum analyzer such as an R&S® FSQ as shown in Fig. 5.

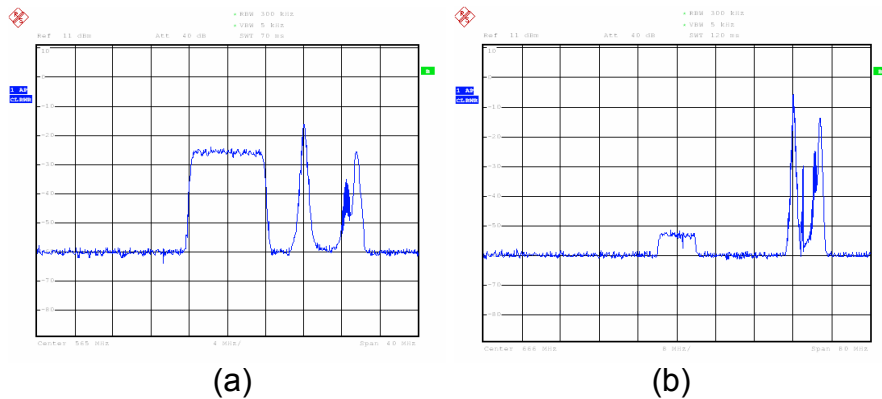

Fig. 6 A significant increase in the interferer power will cause the useful signal to drop its power

Whenever the useful signal power level decreases due to the increased interferer power, an error message, “OUTPUT UNLEVELED” appears. This error indication is useful for a user who wants to ensure that the power of the useful signal is not adversely affected by the interferer. Regardless of the absolute power level, the interferer attenuation will always indicate the correct power difference between the interferer and the useful signal.

Interferer Frequency Offset

A common parameter used in the interference test is the co-location of the interferer with respect to the wanted signal. With this setting, the interferer can be moved to any frequency offset. The maximum offset is specified as ± 40 MHz.

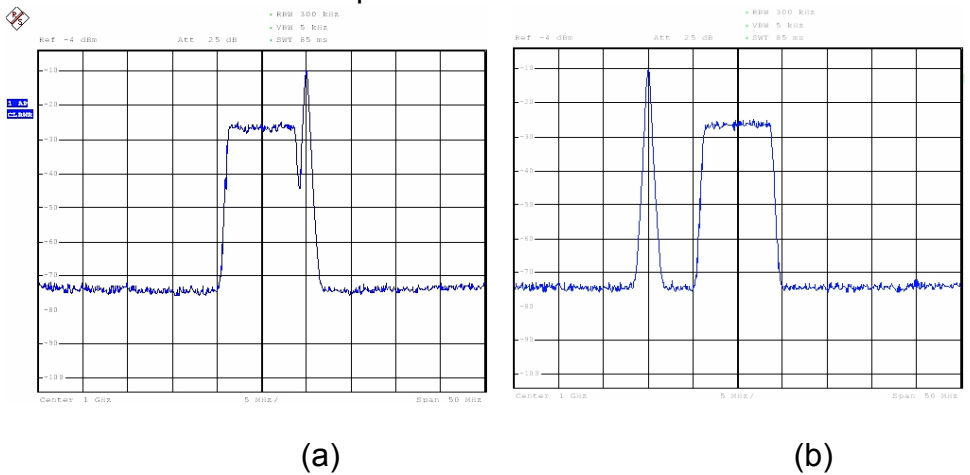

Fig. 7 (a) Interferer is offset at 5 MHz higher and (b) 10 MHz lower than the DVB-T signal

Interferer Addition

In the R&S® SFU a noise generator is available which can generate AWGN (R&S® SFU-K40) or phase noise (R&S® SFU-K41). This menu item offers the flexibility to insert the interferer either before or after the noise is added. This setting also contains a third option, **OFF**, which basically turns off the interferer. Fig. 8 shows the two points at which the interferer can be added.

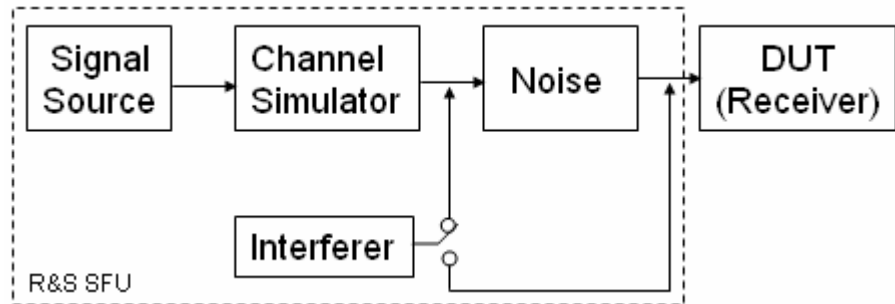

Fig. 8 shows the point of interferer addition in the R&S® SFU

Fig. 9 Addition of interferer before/after noise

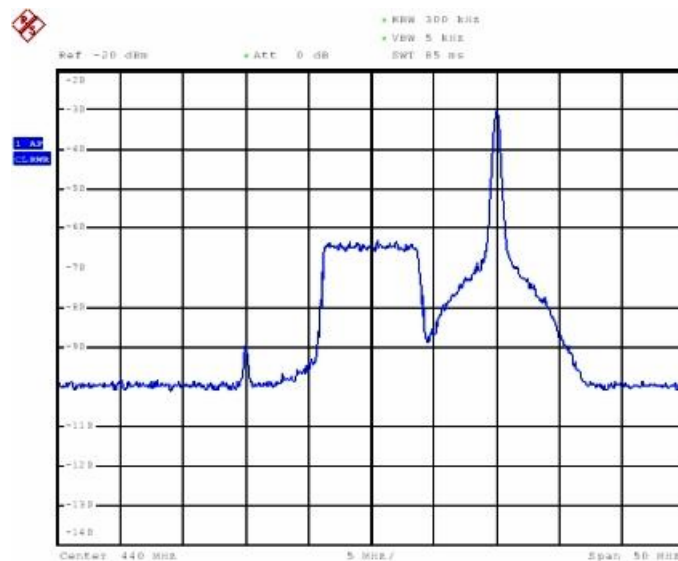

Fig. 9(a) Interferer added before phase noise

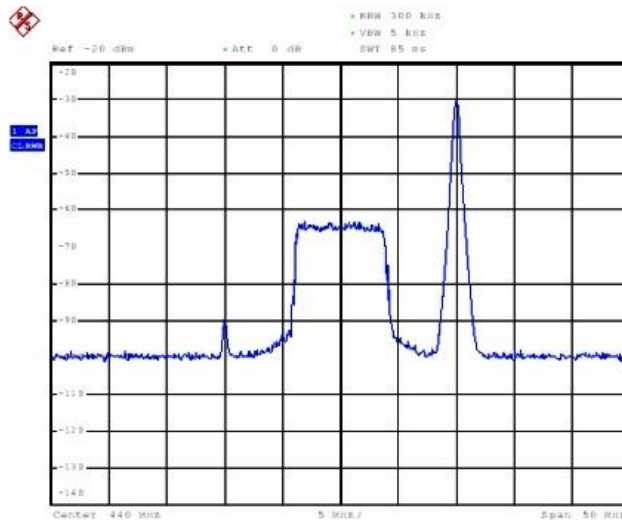

Fig. 9(b) Interferer added after phase noise

Note that only the wanted signal is affected by the noise in (b).

Signal Frequency Offset

With this function, the user can offset the wanted signal with respect to the set RF frequency. The resulting signal frequency is described with the following formula:

$$f_{\text{Signal}} = f_{\text{RF}} + f_{\text{Signal Frequency Offset}} \quad (\text{refer to Fig. 10})$$

The maximum offset is specified as ± 40 MHz. This function can be used to extend the range of frequency offset of the interferer. When this is used together with the interferer frequency offset, the total frequency offset between the interferer and the signal can be increased to ± 80 MHz.

However, a note of caution concerning this technique is to avoid offsetting the useful signal to the image frequency of a strong interferer, as this may give rise to a false result on the receiver performance. Generally, an image interferer appears at $f_{\text{image}} = f_{\text{RF}} + \text{interferer frequency offset}$. Fig. 10 shows that the frequency offset should be used with care.

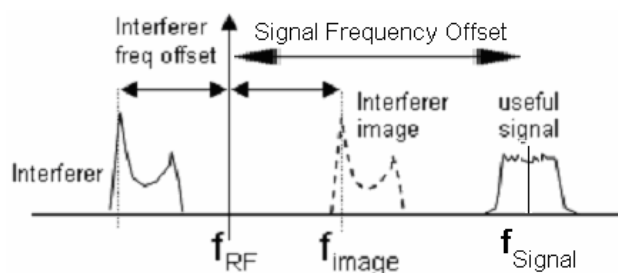

Fig. 10 The useful signal should not be offset to the image frequency (f_{image}) of the interferer

In cases where the effect of the residual carrier at f_{RF} reduces the signal quality (MER not ideal), it is advisable to offset the signal from its center frequency. Thus the residual carrier is no longer present in the useful signal and the MER figure can be improved.

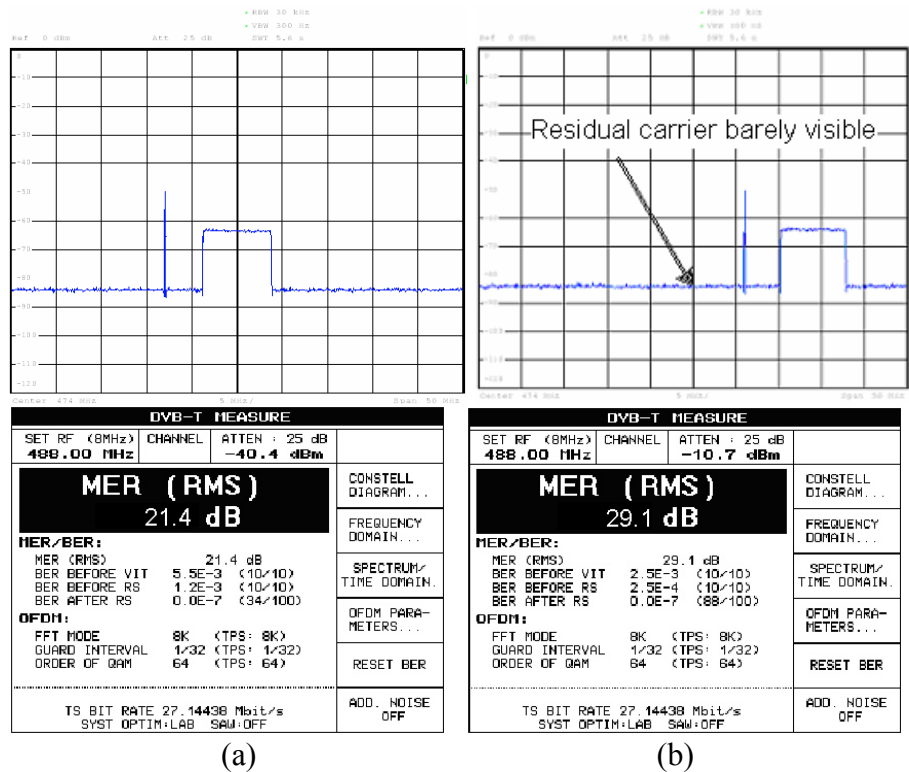

Fig. 11 The effect of offsetting the useful signal away from the residual carrier:

(a) Poor MER due to residual carrier

(b) Improved MER without the effects of residual carrier. Note that the small residual carrier located at the center is barely visible

3 Basic Measurement Techniques

In most cases, the test setup for an interference test on a receiver is as shown in Fig. 12. The signal source provides the wanted signal, and the channel simulator takes care of modulation, up conversion and system impairments. The noise block introduces the noisy environment.

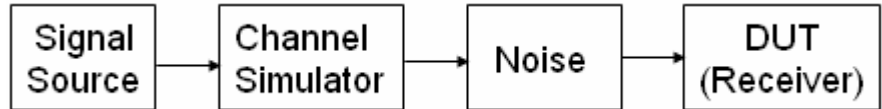

Fig. 12 The measurement setup for an interference test

If an R&S® SFU is used in this measurement setup, it is possible to perform the function of the first three blocks within the R&S® SFU. In addition to the noise, it is now possible to introduce an interferer with the new R&S® SFU-K37 option.

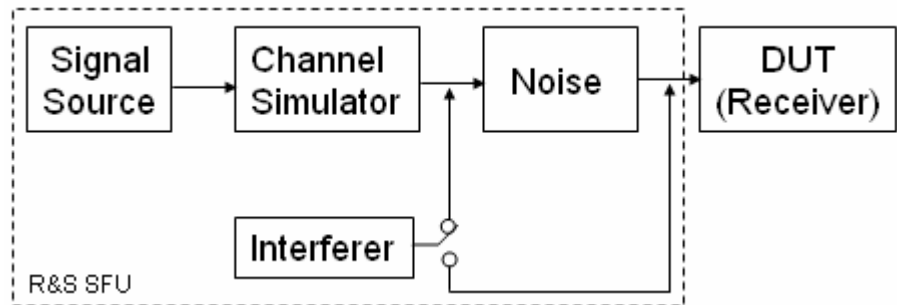

Fig. 13 The addition of the R&S® SFU-K37 option in R&S® SFU

With an increasing growth in the deployment of various transmission systems, the interferer offers a critical but realistic condition to evaluate the performance of the DUT.

Fig. 14 shows a screen dump of an analog PAL TV interferer signal which is offset at 8 MHz higher than the wanted DVB-T signal.

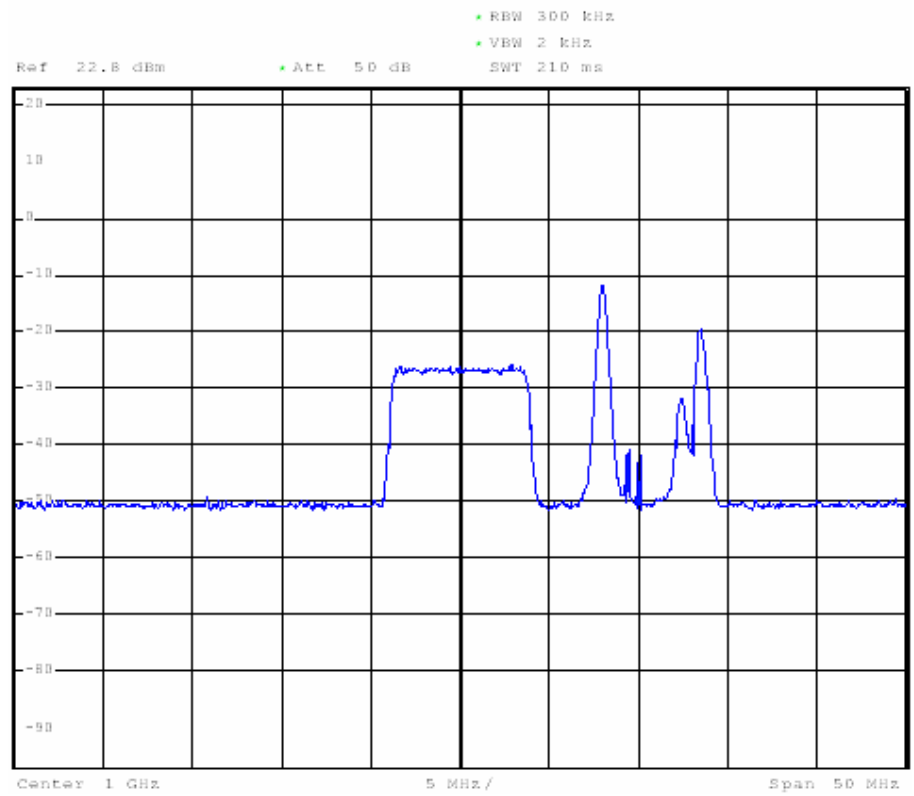
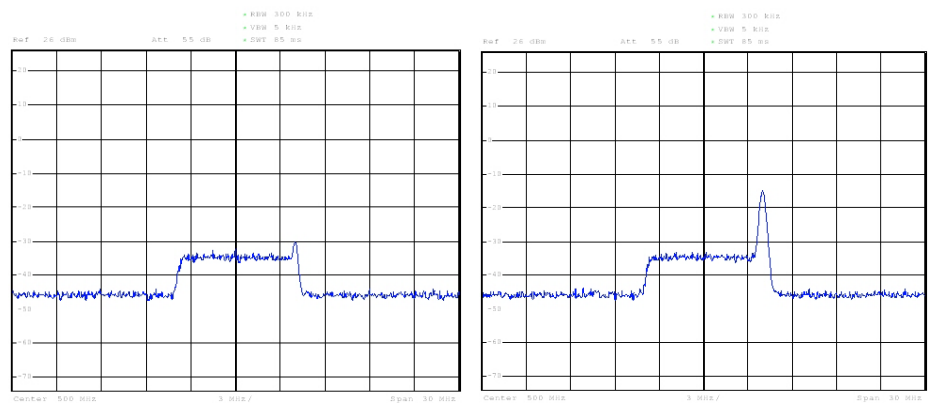

Fig. 14 A PAL TV interferer signal in the vicinity of a DVB-T signal

To observe the impact of an interferer on a signal, we can see from Fig. 13 that by increasing the level of the interferer from +10 dB to -5 dB, the MER(rms) of the DVB-T signal decreases by 3.5 dB.



DVB-T MEASURE		
SET RF (MHz)	CHANNEL	ATTEN : 25 dB
500.00 MHz		86.3 dBuV
MER (RMS)		CONSTELL. DIAGRAM...
37.6 dB		FREQUENCY DOMAIN...
MER/BER:		SPECTRUM/TIME DOMAIN...
MER (RMS)	37.6 dB	
BER BEFORE VIT	5.1E-9 (132/1K00)	
BER BEFORE RS	0.0E-9 (100/1K00)	
BER AFTER RS	0.0E-8 (103/1K00)	
OFDM:		OFDM PARAMETERS...
FFT MODE	8K (TPS: 8K)	
GUARD INTERVAL	1/32 (TPS: 1/32)	
ORDER OF QAM	64 (TPS: 64)	
		RESET BER
TS BIT RATE 27.14438 Mbit/s		ADD. NOISE OFF
SYST OPTIM:FAST SAW:8.0MHz		

(a)

DVB-T MEASURE		
SET RF (MHz)	CHANNEL	ATTEN : 25 dB
500.00 MHz		89.8 dBuV
MER (RMS)		CONSTELL. DIAGRAM...
34.1 dB		FREQUENCY DOMAIN...
MER/BER:		SPECTRUM/TIME DOMAIN...
MER (RMS)	34.1 dB	
BER BEFORE VIT	1.2E-5 (10/10)	
BER BEFORE RS	1.6E-8 (483/1K00)	
BER AFTER RS	9.3E-8 (505/1K00)	
OFDM:		OFDM PARAMETERS...
FFT MODE	8K (TPS: 8K)	
GUARD INTERVAL	1/32 (TPS: 1/32)	
ORDER OF QAM	64 (TPS: 64)	
		RESET BER
TS BIT RATE 27.14438 Mbit/s		ADD. NOISE OFF
SYST OPTIM:FAST SAW:8.0MHz		

(b)

Fig. 15 The effect of the interferer attenuation on the DVB-T signal; before (a) and after (b) reduction in interferer attenuation

The closeness of the interfering frequency to the wanted signal is also an important parameter which can affect the performance of a receiver. To observe this condition, Fig. 16 shows that by moving the interferer to beyond 10 MHz of the wanted signal, the MER(rms) of the DVB-T signal improves by more than 10 dB.

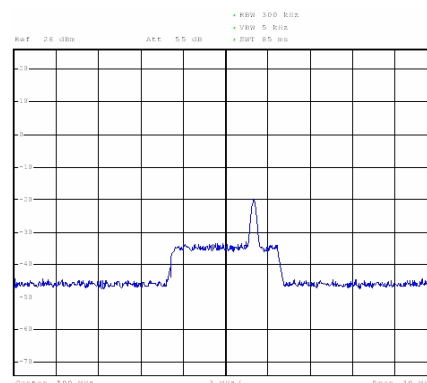

DVB-T MEASURE		
SET RF (MHz)	CHANNEL	ATTEN : 25 dB
500.00 MHz		89.4 dBuV
MER (RMS)		CONSTELL. DIAGRAM...
27.3 dB		FREQUENCY DOMAIN...
MER/BER:		SPECTRUM/TIME DOMAIN...
MER (RMS)	27.3 dB	
BER BEFORE VIT	5.0E-3 (10/10)	
BER BEFORE RS	1.8E-3 (10/10)	
BER AFTER RS	8.2E-9 (2K48/10K0)	
OFDM:		OFDM PARAMETERS...
FFT MODE	8K (TPS: 8K)	
GUARD INTERVAL	1/32 (TPS: 1/32)	
ORDER OF QAM	64 (TPS: 64)	
		RESET BER
TS BIT RATE 27.14438 Mbit/s		ADD. NOISE OFF
SYST OPTIM:FAST SAW:8.0MHz		

(a)

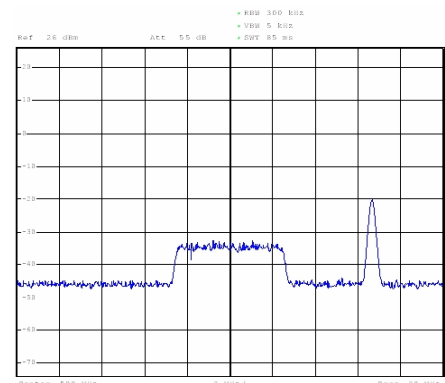

DVB-T MEASURE		
SET RF (MHz)	CHANNEL	ATTEN : 25 dB
500.00 MHz		86.5 dBuV
MER (RMS)		CONSTELL. DIAGRAM...
37.7 dB		FREQUENCY DOMAIN...
MER/BER:		SPECTRUM/TIME DOMAIN...
MER (RMS)	37.7 dB	
BER BEFORE VIT	0.0E-10 (1K12/10K0)	
BER BEFORE RS	0.0E-9 (915/1K00)	
BER AFTER RS	0.0E-8 (953/1K00)	
OFDM:		OFDM PARAMETERS...
FFT MODE	8K (TPS: 8K)	
GUARD INTERVAL	1/32 (TPS: 1/32)	
ORDER OF QAM	64 (TPS: 64)	
		RESET BER
TS BIT RATE 27.14438 Mbit/s		ADD. NOISE OFF
SYST OPTIM:FAST SAW:8.0MHz		

(b)

Fig. 16 The closeness of the interferer determines the level of impact on the wanted signal; before (a) and after (b) moving interferer away from the wanted signal

4 The Performance of the R&S® SFU-K37 Interferer Option

The different test specifications for minimum receiver requirements demand certain carrier-to-interference relations. Therefore the R&S® SFU-K37 offers a wide range of configurability.

As the used digital/analog converter has a resolution of 16 bit, the I/Q modulator provides an overall dynamic range of 96 dB, which allows the output of the useful signal and possible interferers in line with nearly all relevant test specifications for receiver terminals.

As a meaningful example for interferer performance, the following section shows how the R&S® SFU can be used to determine the conformance of a terminal to a MBRAI test case. For further details about MBRAI, please refer to [2].

Adjacent Channel Tests in Line With IEC 62002-2

Test pattern L1, consisting of a DVB-T and analog interferer signal, is defined as follows:

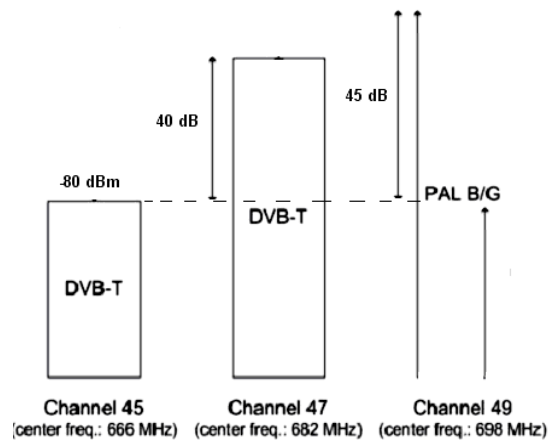

Fig. 17 Immunity to interferer pattern L1 in line with IEC 62002-2

To specify the analog and digital interferers on the R&S® SFU, apply the following settings:

FREQUENCY 674.000 000 0 MHz		LEVEL -49.0 dBm	STANDARD DVB-T/H	MODE 8K	BANDWIDTH 7.607 MHz
NOISE OFF	FADING OFF	USER1	USER2	USER3	REF INT

SELECTION	MODULATION	
FAVORITES	MODULATION	ON
FREQUENCY	SIGNAL SOURCE	DTV
SWEEP	TRANSMISSION STANDARD	DVB-T/H
SETTINGS	SPECTRUM	NORMAL
LEVEL	INTERFERER SOURCE	ATV PREDEF.
MODULATION	ATV PREDEFINED STANDARD	DVB-T + PAL G (MBRAI)
SETTINGS	INTERFERER ATTENUATION	-46.00 dB
SIGNAL INFO/STAT.	INTERFERER FREQUENCY OFFSET	16.000 000 0 MHz
CODING	INTERFERER ADDITION	AFTER NOISE
IMPAIRMENTS	SIGNAL FREQUENCY OFFSET	-8.000 000 0 MHz
NOISE	BACK	
FADING		

I/C

1. Select “ATV PREDEF.” as the interferer source.
2. Choose the desired kind of interferer signals: You can choose between single and multiple interferer in accordance with the MBRAI specifications. For the L1 scenario, select “DVB-T + PAL G (MBRAI)”.
3. In order to generate the useful signal at 666 MHz, a special frequency configuration is required. Due to the default alignment of the interferer signal, a frequency shift to the set output frequency is necessary. Set the INTERFERER FREQUENCY OFFSET to 24.0 MHz (3 x 8 MHz, due to channel spacing).

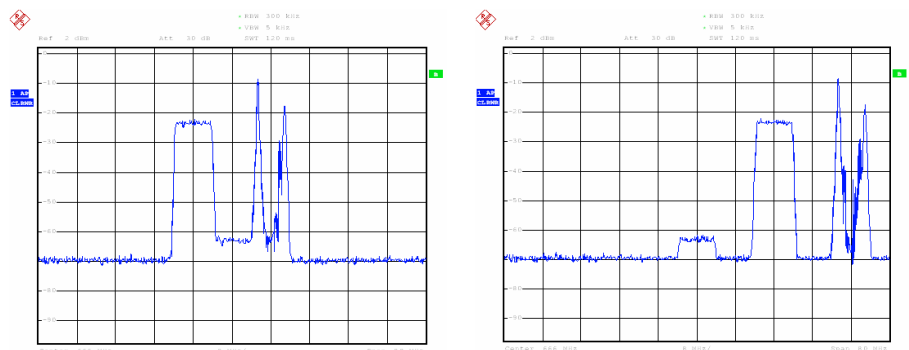

Fig. 18: Interferer frequency offset = 0 MHz and 24 MHz

4. In order to avoid any negative influences of the residual carrier, it is advisable to use a configuration which ensures that the residual carrier is not part of the useful signal.

Therefore the set output frequency of the R&S® SFU needs to be outside the tested signal.

For this purpose, the item SIGNAL FREQUENCY OFFSET has been introduced. It allows a frequency offset from the

residual carrier, which exists at the set output frequency of the R&S®SFU.

To generate a realtime modulated signal at 666 MHz without any residual carrier influence, apply the following settings:

- Set the actual R&S®SFU output frequency to 674 MHz
- Apply an INTERFERER FREQUENCY OFFSET of 16 MHz and a SIGNAL FREQUENCY OFFSET of -8 MHz, as shown in the figure on page 15.

5. In this case, it is advisable to calibrate the vector modulator. To do this, select the SETUP key:



Or select SETUP from the menu:



In the window which appears, go to ADJUSTMENT and execute the VECTOR MODULATION LOCAL function:

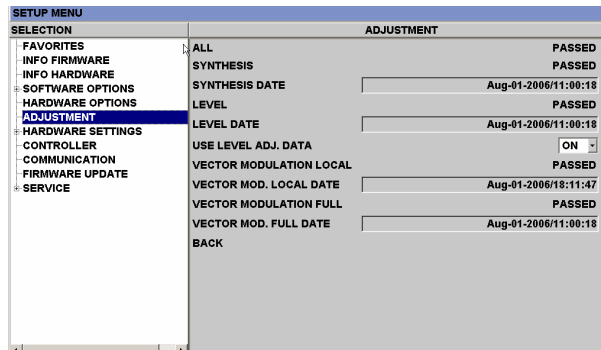

6. To activate interferer addition, select the desired interferer addition mode. If no phase noise is active, “after noise” addition is the same as “before noise” addition.
7. Finally, adjust interferer attenuation in order to determine the MBRAI compliance (marked in red in the figure on page 15).

Performance Clearance of the R&S® SFU-K37 Interferer Option

As described earlier in this section, the R&S® SFU provides 96 dB overall dynamic. The interferer signal as well as the useful signal must be properly modulated. The considerations also need to cover the crest factor of the two signals.

This dynamic range is definitely large enough for performing MBRAI conformance testing. In order to show the performance, an example measurement has been processed showing the limit conditions at which the R&S SFU is able to generate valid signal scenarios.

The following test setup was used for the measurement:

R&S SFU S/N 100170:	R&S EFA S/N 847257/014
<i>LEVEL: -50 dBm</i> <i>FREQUENCY: 474 MHz</i> <i>SIGNAL FREQUENCY OFFSET:</i> <i>-24 MHz (8 MHz), -21 MHz (7 MHz)</i> <i>INTERFERER FREQUENCY</i> <i>OFFSET = 0 Hz</i> <i>INT. ATT. = -C/I</i> <i>DVB-T</i> <i>8K</i> <i>Guard 1/32</i> <i>Rate ¾</i>	<i>SAW 8 MHz</i> <i>SYSTEM OPT.: STATIONARY</i> <i>FAST/SFN</i> <i>FREQ REC LOOP BW: MED</i>

For a 16 QAM modulation and an L1 (PAL B/DVB-T) interferer, the minimum available interferer attenuation C/I for quasi error-free measurement equals **-54 dB**.

5 Summary

The R&S® SFU-K37 option offers great ease and flexibility for a communications engineer to analyze and measure the performance of a receiver under the influence of a nearby interferer. The ability to manipulate the characteristics of the interferer allows the analyst to subject the wanted signal to various interferer patterns and to obtain accurate results regarding receiver performance.

6 References

- [1] International Electrotechnical Commission (Ed.) (2005). International Standard IEC 62002-1. Mobile and portable DVB-T/H radio access – Part 1: Interface specification. International Electrotechnical Commission.
- [2] International Electrotechnical Commission (Ed.) (2005). International Standard IEC 62002-2. Mobile and portable DVB-T/H radio access – Part 2: Interface conformance testing. International Electrotechnical Commission.
- [3] Gsoedl, Harald (2006). Application Note 7BM61_0E. *Creating Test Scenarios in Accordance with IEC 62002 (MBRAI) Using the R&S® SFU*. Munich: Rohde & Schwarz GmbH & Co. KG website: <http://www.rohde-schwarz.com>.

7 Ordering Information

Type	Designation	Order no.
R&S SFU	Broadcast Test System	2110.2500.02
R&S SFU-B1	Coder Extension 1	2110.7424.02
R&S SFU-B10	Coder Extension 10	2110.7747.02
R&S SFU-B11	ETI Input/Output	2110.7553.03
R&S SFU-B2	Coder Extension 2	2110.8089.02
R&S SFU-B3	Memory Extension 1	2110.7447.02
R&S SFU-B30	Fading Simulator	2110.7530.02
R&S SFU-B31	Fading Simulator Extension to 40 Paths	2110.7547.02
R&S SFU-B4	Memory Extension 2	2110.7453.02
R&S SFU-B5	User I/O	2110.7460.02
R&S SFU-B6	Additional Hard Disk	2110.7501.02/03
R&S SFU-B90	High Power and Overvoltage Protection	2110.8008.02
R&S SFU-K1	DVB-T/H Coder	2110.7301.02
R&S SFU-K10	MediaFLO Coder	2110.7524.02
R&S SFU-K108	AMC Coder	only on request
R&S SFU-K11	T-DMB/DAB Coder	2110.7518.02
R&S SFU-K120	DMB-TH Coder	2110.7760.02
R&S SFU-K190	ATV Standard B/G Coder	2110.8050.02
R&S SFU-K191	ATV Standard D/K Coder	2110.8037.02
R&S SFU-K192	ATV Standard I	2110.8043.02
R&S SFU-K193	ATV Standard M/N Coder	2110.8066.02
R&S SFU-K194	ATV Standard L Coder	2110.8072.02
R&S SFU-K199	Multi ATV Predefined	2110.8089.02
R&S SFU-K2	DVB-C Coder	2110.7324.02
R&S SFU-K20	TS Generator	2110.7476.02
R&S SFU-K21	TS Recorder	2110.7482.02
R&S SFU-K22	TRP Player	2110.7499.02
R&S SFU-K221	T-DMB/DAB Streams	2110.4348.02
R&S SFU-K23	Video Generator	2110.7799.02
R&S SFU-K3	DVB-S/DSSNG Coder	2110.7330.02
R&S SFU-K30	Enhanced Fading	2110.7560.02
R&S SFU-K32	DAB Gaussian Fading	2110.7630.02
R&S SFU-K35	ARB Generator	2110.7601.02
R&S SFU-K351	T-DMB/DAB Waveforms	2110.4277.02
R&S SFU-K352	DVB-H Waveforms	2110.4425.02
R&S SFU-K353	DRM Waveforms	2110.4554.02
R&S SFU-K354	DTV Interferers	2110.4690.02
R&S SFU-K4	ATSC/8VSB Coder	2110.7353.02
R&S SFU-K37	Interferer Management	2110.7647.02
R&S SFU-K40	Noise AWGN	2110.7653.02
R&S SFU-K41	Phase Noise	2110.7660.02
R&S SFU-K42	Impulsive Noise	2110.7676.02
R&S SFU-K43	Multinoise Use	2110.7682.02
R&S SFU-K5	J.83/B Coder	2110.7360.02
R&S SFU-K6	ISDB-T Coder	2110.7376.02
R&S SFU-K60	BER Measurements	2110.7782.02
R&S SFU-K7	DMB-T Coder	2110.7382.02
R&S SFU-K8	DVB-S2 Coder	2110.7399.02
R&S SFU-K80	Extended I/Q	2110.7953.02
R&S SFU-K81	Realtime Disabled	2110.7960.02
R&S SFU-K82	Realtime Enabled	2110.7976.02
R&S SFU-K9	DIRECTV	2110.7401.02
R&S SFU-U43	Upgrade Kit for R&S SFU-K43	2110.7699.02
R&S DV-DVBH	DVB-H Stream Library	2085.8704.02
R&S DV-H264	H.264 Stream Library	2085.7650.02
R&S DV-HDTV	HDTV Sequences	2085.7650.02
R&S DV-ISDBT	ISDB-T Stream Library	2085.9146.02
R&S DV-TCM	Test Card M Streams	2085.7708.02



ROHDE & SCHWARZ GmbH & Co. MuhldorfstraBe 15 D-81671 Munchen P.O.B 80 14 69 D-81614 Munchen

Telephone +49 89 4129-0 Fax +49 89 4129 – 1377 Internet: <http://www.rohde-schwarz.com>

This Application Note and the supplied programs may only be used subject to the conditions of use set forth in the download area of the Rohde & Schwarz website.